

# Cassina

LC2

Family LC

Catalogue I Maestri

Year of design 1928

Year of production 1965

*Fauteuil Grand Confort, petit modèle*

Armchair, two- or three-seater sofas and ottoman with polished trivalent chrome plated (CR3) or semigloss grey, light blue, green, brown, mud, ivory or black enamel steel frame. Loose cushions with polyurethane foam and polyester padding or padding in feather (excluding the ottoman) with polyurethane core. Leather or fabric upholstery; a technical microfibre fabric only for models with chrome plated frame is also available.

Yet another timeless classic, one that made design history. Designed in 1928, it is the archetype of the modern chair. The careful separation of the caged frame from its inner cushions are a concrete affirmation of the chair's rationalist approach. A true classic.

## Gallery

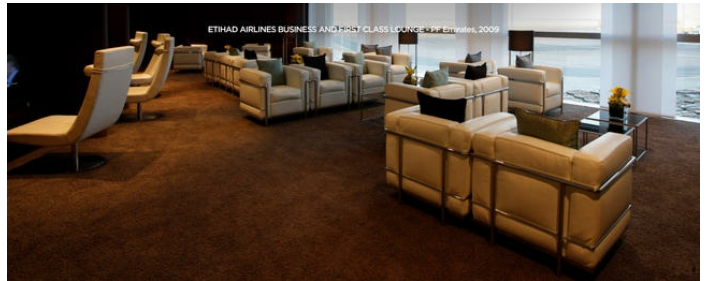



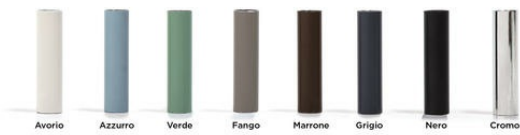

## Dimensions

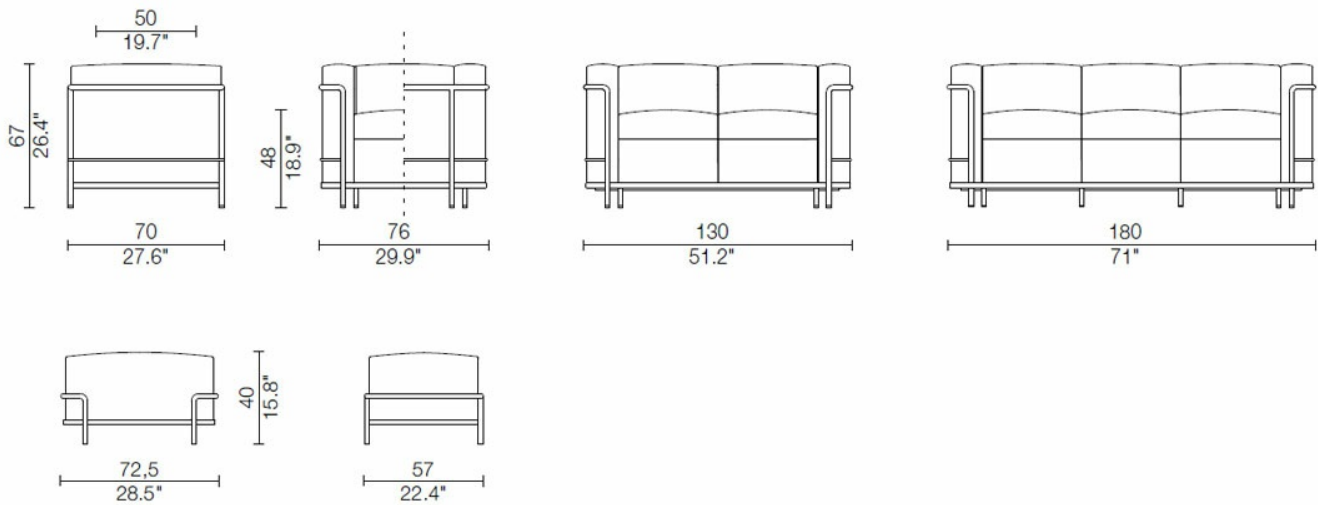

## Authenticity

All the models in the Cassina collection, by merit of their artistic content and particular creative character, are protected by copyright, a legal institution that is universally recognised and safeguarded; legal protection is assured for the whole life-span of the author and for 70 years after his/her death (or the death of the last surviving co-author).

## Designer



**Le Corbusier, Pierre Jeanneret, Charlotte Perriand**

In 1922, Le Corbusier began working in the new rue de Sèvres, Paris, atelier with his cousin Pierre Jeanneret with whom he shared research projects and design criteria in a profound and life-long professional relationship.

In October 1927, the pair decided to draw on the contribution of a young architect who had already begun to establish a reputation on the architectural scene of the time: Charlotte Perriand.

Their collaboration lasted through to 1937 and was extremely fruitful, especially in the field of furniture design. The partnership was highly significant, both in terms of the cultural weight of their achievements and their professional successes.

It was together with Charlotte Perriand that the pair tackled the innovative project for "l'équipement d'intérieur de l'habitation".

The resulting designs were of great intellectual value and considerable commercial success.

Thanks to Cassina's ongoing production, there is continued interest in the conceptual contents of the work and the level of quality attained.

Due to these characteristics, each item in the collection is eagerly awaited.

<http://www.fondationlecorbusier.fr/>