

# Cassina

905

Year of design 1964

Produced by Cassina until 2000, this chair has now been relaunched, the finishes and details having been updated from the original archive model. The sophisticated elegance of the frame, which features cylindrical legs and curved arm-rests, has been rejuvenated thanks to Cassina's extensive experience in handling leather, not to mention the company's high quality carpentry skills. The complex nature of this piece is expressed in a design that looks simple but fully reflects the genius quality of the original concept, a veritable masterpiece of the crafts tradition proper to Meda, in the Brianza area north of Milan, and known as MedaMade, the trademark registered by Cassina and a guarantee of utmost quality. The frame, in finest quality wood, bespeaks the perfect combination of the artisanal tradition and premier CNC technology, while the overall design stands out for the self-supporting seat crafted from one single piece of saddle leather, curved and slotted into the frame. The decorative stitching has been discontinued, while the rear of the chair still features the leather belt that lends support to the back and enhances its comfort quotient.

## Gallery





## Dimensions

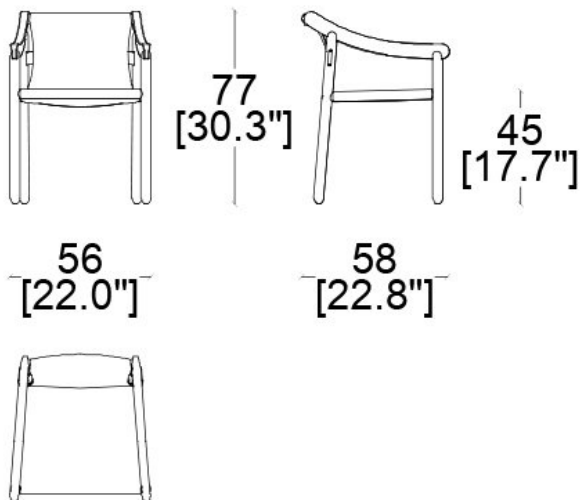

## Designer

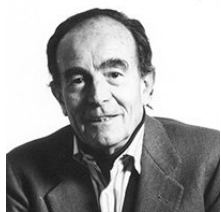

**Vico Magistretti**

In 1920 Magistretti was born in Milan, the city in which he graduated in architecture in 1945, and where his professional career has spun its story ever since, chiefly in the fields of architecture, town planning and industrial design. The first recognition of his work came in 1948, when he won the Gran Premio at the 8th Triennale. After that came almost forty years of activity with other prizes and awards in recognition of Magistretti's work in various sectors in different countries.

Giving lessons and lectures in various faculties of architecture and schools of design in Italy and abroad, from Milan to New York, from Paris to London, a city to which he is particularly devoted, he has been an "Honorary Fellow" of the Royal College of Art since 1983.

Furniture, lamps and other objects that he designed may be found all over the world and the most important design museums have given exhibitions in his honour and kept examples of his work in their permanent collections. Magistretti's research has been continuous - into design, the culture of the project and innovative experimentation with materials and space solutions, not to mention shapes and functions far from the rigours of fashion that they have passed through during the years. He started designing for Cassina in 1960, and from that date on his signature is to be found on very many products. We recall in particular the Maralunga sofa of 1973 and the Nuvola Rossa (1977) bookcase, which are still indisputable international best-sellers and have provoked hordes of imitations which have not been able to echo even faintly the success of the originals.

<http://www.vicomagistretti.it>