

# Cassina

## 081 RÉACTION POÉTIQUE

Catalogue I Contemporanei

Year of production 2015

This collection of objects, inspired by the pictorial works of Le Corbusier and designed by Jaime Hayon, now comes in a wider range of finishes. As well as the original blackstained solid ashwood, in which it was presented in 2015, four new finishes are now also available: green oil stained, purple red stained, mud stained ashwood, open pore and matt natural American walnut.

### Gallery

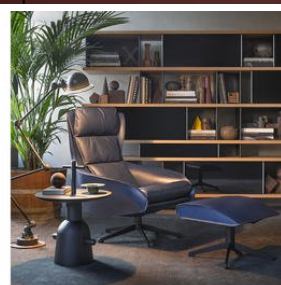
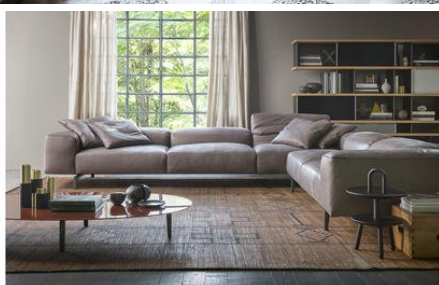
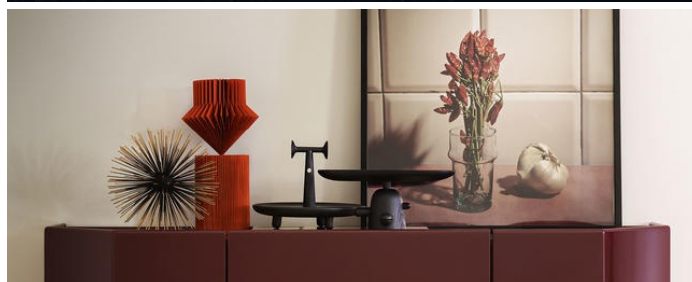
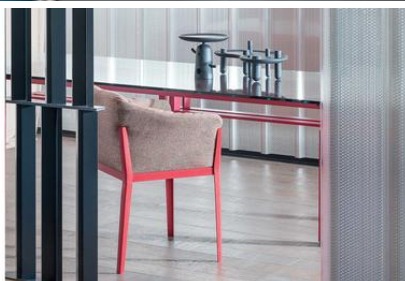





## Dimensions



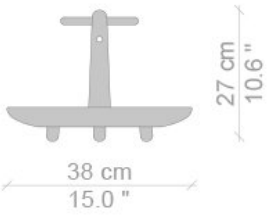
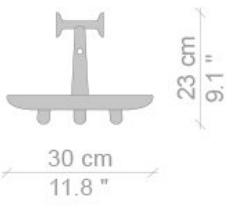

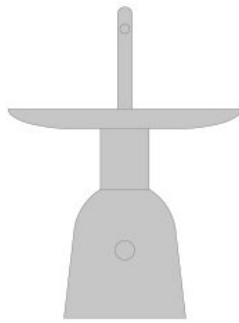
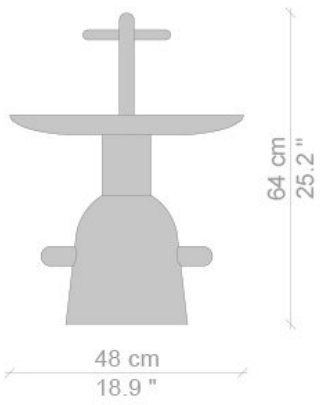
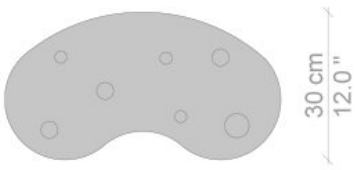
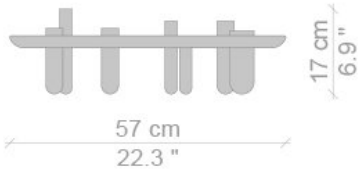



## Designer



**Jaime Hayon**

Spanish artist-designer Jaime Hayon was born in Madrid in 1974. After studying industrial design in Madrid and Paris he joined Fabrica – the Benetton-funded design and communication academy in Italy- in 1997 where he directed the design department until 2003. Hayon set up his own studio practice in the year 2000 and dedicated himself fully to his personal projects from 2003 onward, today he is one of the most acclaimed creators worldwide. His singular vision was first fully exposed in 'Mediterranean Digital Baroque' at London's David Gill Gallery, followed by many exhibitions and installations set up in major galleries and museums worldwide in venues like the: Vivid Gallery, Mak Vienna, Groninger Museum, Aram Gallery, London's Design Museum, Mudac museum, Gallery Thomas in Munich, Walker art center, Centre Pompidou, as well as the Basel Art Fair, to name a few, attracting the attention of prestigious art collectors worldwide. Today his works are in the permanent collections of some of these institutions. Hayon's esteem and knowledge of artisan skills and his inherent creativity has allowed him to push the boundaries of many mediums and functions, resulting in collections for very diverse clients. His concern for the conservation of craft skills has joined his path with high-end traditional companies concerned with the evolution of their work. Examples of this are his collaborations with Baccarat, Choemon in Japan, Bosa Ceramiche and Lladro. He has created furniture ranges for iconic danish company Fritz Hansen, Magis, Established and Sons, Bisazza, B.D. Barcelona, Se London, Bernhardt Design, Ceccotti and Moooi. Hayon has designed various lighting fixtures collections for Metalarte and also in collaboration with Swarovski and Baccarat. He has created accessories for Piper Heidsieck, Gaia and Gino, The Rug Company. These collections have put Jaime at the forefront a new wave of creators that blurred the lines between art, decoration and design and a renaissance in finely-crafted, intricate objects within the context of contemporary design culture. Adding to his acclaimed intramurals for Madrid's La Terraza del Casino restaurant and Camper footwear stores, Jaime is currently working on interiors for leading hotels, restaurants and retail establishments around the world that have become platforms to create special objects and functional and non functional elements. Most recently, he has completed Octium, a jewelry shop in Kuwait, the Faberge Salon in Geneva, Switzerland and the Info Center for the Groninger Museum in the Netherlands. Hayon's latest Restaurant, Le Sergeant Recruteur in Paris, is a good example of elegance and artistic approach to the interior world. His work has appeared in the most prestigious art and design publications worldwide. He has won numerous awards including 'Best Installation' by Icon Magazine, 'Breakthrough Creator' by Wallpaper Magazine, Elle Deco International Award 2006 and 2012, Elle Deco Germany: 'Best International Designer' 2008, 'BEST DESIGNER' for ELLE DECO JAPAN in 2008, AD RUSSIA 'DESIGNER OF THE YEAR' 2009, MAISON OBJET DESIGNER OF THE YEAR 2010, among many others. In 2008, Jaime was guest of honor at Belgium's Interieur Biennial, the youngest person ever to receive the accolade. Times magazine included Hayon as one of the 100 most relevant creators of these times and Wallpaper magazine has listed him as one of the most influential creators too. With offices in Italy, Spain and Japan, Hayon's main interest is to find challenges and new perspectives continuously.