



HARTÔ

PARIS

COLLECTION 2018





PARIS

## EDITO

Chez HARTÔ, nous aimons les meubles et les objets faciles à vivre. Nous pensons que notre intérieur doit s'adapter à nos modes de vie et à nos habitudes. C'est pour cela que notre créativité se nourrit du quotidien pour vous proposer de belles pièces qui ont cette petite touche fonctionnelle en plus.

At HARTÔ, we love furniture and objects that are practical. We believe that interiors should adapt seamlessly to our lifestyle, every day. This focuses our creativity on merging the practical aspects of every day living while adding that special finishing and functional touch that catches the eye.



# JOSETTE *Pauline Gilain & Pierre-François Dubois*



bois / wood



hêtre / ash

couleurs avec tablette bois /  
colors with wood tablet



couleurs avec tablette peinte /  
colors with painted wood tablet



hêtre / ash



## Lampe-guéridon

Frêne massif et tablette inférieure en métal laqué, finitions mates, abat-jour en coton, câble blanc en coton, ampoule E27, 23W max.  
Blanc, bleu d'eau, rose pomelo, bordeaux, blanc lin, bleu marine.

## Table-lamp

Solid ash and lacquered metal table, cotton lampshade, white textile cord, E27 bulb, max 23W.  
White, water blue, pomelo pink, bordeaux, white linen, navy blue.

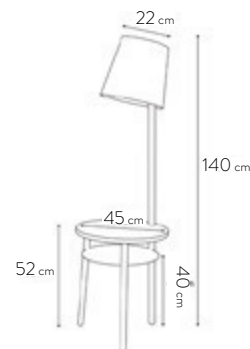

# ÉLISABETH *Julien Phedyaeff*



couleurs / colors



## Lampadaire tripode

Structure en métal laqué, finitions mates. Câble métallique tendu le long de la lampe. Interrupteur au pied, ampoule E27, 23W max.  
White, slate grey, lemon yellow.

## Trivet floor lamp

Structure made of lacquered metal, matt finish. Wire cable stretched along the lamp. Foot-switch., E27 bulb, max 23W.  
White, slate grey, lemon yellow.

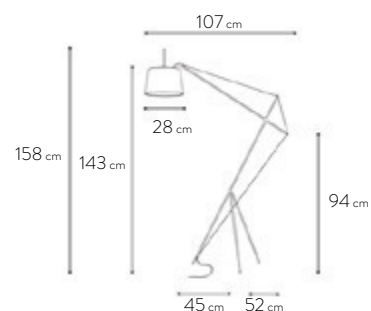

# NUANCIER PRINCIPAL

## Main colors

 Blanc  
White  
RAL 9016

 Gris clair  
Light grey  
RAL 7035

 Gris ardoise  
Slate grey  
RAL 7016

 Rose pale  
Light pink  
NCS S 0515-R

 Rose abricot  
Apricot pink  
NCS S 0530-Y80R

 Rose Pomelo  
Pomelo pink  
NCS S 3050-Y90R

 Corail  
Coral  
NCS S 0550-Y90R

 Rouge cerise  
Cherry red  
RAL 3003

 Bordeaux  
Bordeaux  
RAL 3005

 Bleu pale  
Light blue  
NCS S 1510-B

 Bleu marine  
Navy blue  
RAL 5003

 Bleu réaliste  
Realistic blue  
RAL 5002

 Bleu gris  
Grey blue  
NCS S 6020-R90B

 Bleu pétrole  
Petrol blue  
RAL 5020

 Bleu d'eau  
Water blue  
RAL 5021

 Vert céladon  
Celadon green  
NCS S 2020-B90G

 Vert pastel  
Pastel green  
RAL 6019

 Vert de gris  
Greyish green  
RAL 6021

Nos remerciements à **TH Manufacture** ainsi qu'au concept store **Fleux'** pour le prêt des objets ne faisant pas partie de notre collection. Les photos, illustrations et légendes de ce catalogue sont non-contractuelles. / *Pictures and comments are for purpose only.*



PARIS

SIEGE SOCIAL  
HEADQUARTERS

52 rue de Turbigo  
75003 Paris

@: [contact@hartodesign.com](mailto:contact@hartodesign.com)  
Tel: +33 (0)1 83 56 45 47

CONTACT PRESSE  
PRESS CONTACT

France :  
[b.korb@bmrp.fr](mailto:b.korb@bmrp.fr), [p.lazarus@bmrp.fr](mailto:p.lazarus@bmrp.fr)  
Outside France :  
[contact@hartodesign.com](mailto:contact@hartodesign.com)

PHOTOGRAPHERS  
PHOTOGRAPHERS  
Thierry Caron, Alexis Narodetzky,  
Hervé Goluza, Pedro Saraiva