

> INSTRUCTIONS MANUAL <

CAN SOFA

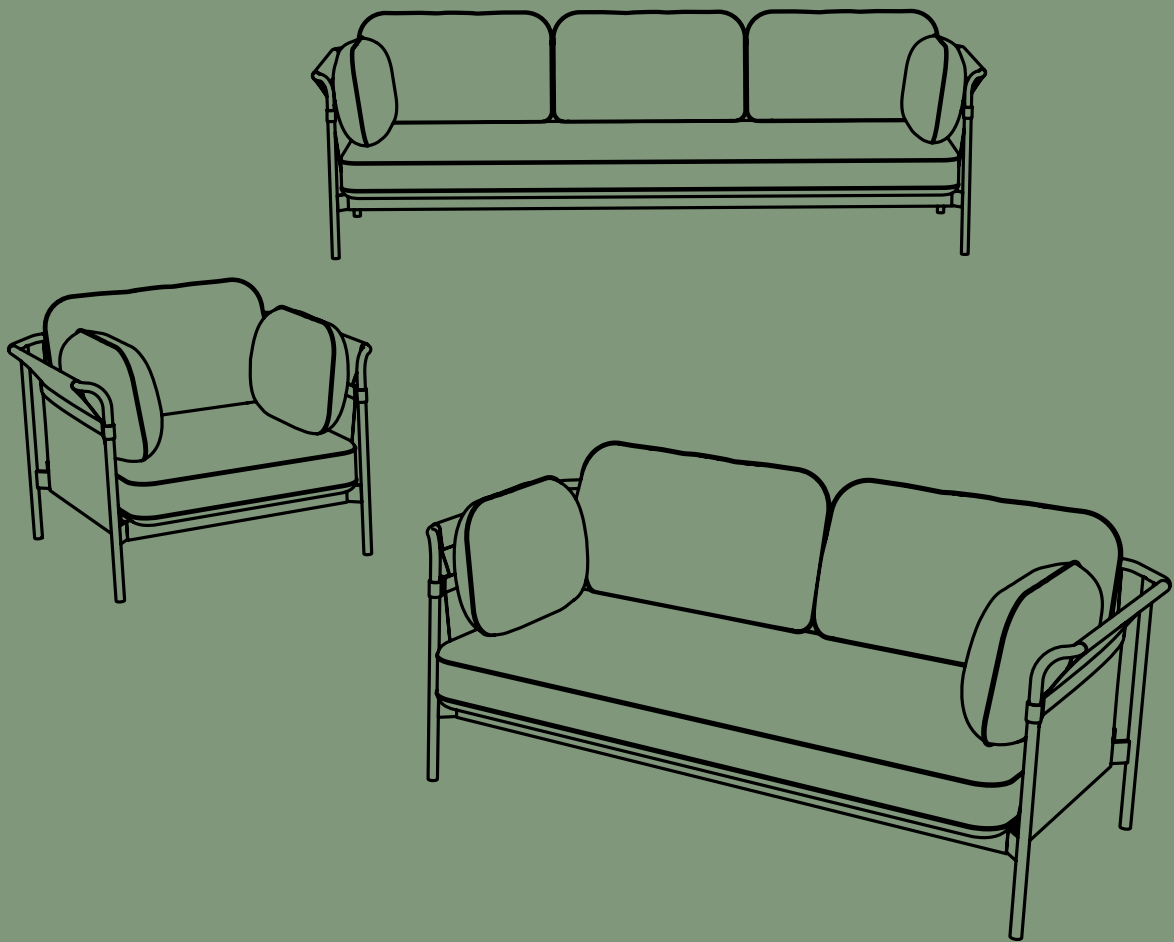

BY RONAN & ERWAN BOUROLLEC

HAY

In the Can sofa, Ronan and Erwan Bouroullec are seeking to go beyond the creation of a practical, elegant and comfortable design. The intention is to reinvigorate the whole idea of the sofa, from something inherently complicated, to something simple, relaxed and for everyone.

The sofa comes flat-packed and is assembled at home as we believe people are keen to get things in a quick and simple way, it is better for all resources, it is less transportation, less volume, less stock, it is just much easier to do.

The idea of the name Can is that “you can”, “you can make it”, just don’t be afraid. Maybe the sofa will raise the fear “can I do this?”, “is it going to be right?” So, it is implemented into the name itself, just don’t be afraid, it will work.

CAUTION

With a little care you can prolong the life of your furniture and keep the foam and fabric in good condition. HAY only uses top quality fabrics, but all fabrics fade, and seams will weaken when exposed to sunlight.

- Protect your sofa against direct sunlight and strong heat sources.

- Flip the cushions regularly to avoid patinating on one side only.

- Make sure to lift the furniture rather than pulling or pushing it to avoid damaging the floor, legs and mountings.

- Tighten up the screws after one to two months' use.

- Avoid improper use such as sitting on the back or armrests and standing on it.

- Smooth out creases and wrinkles with your hand after use to even out the fabric and prevent seam lines from being skewed.

- Plump the cushions regularly to maintain the shape.

POWDER COATED STEEL

- Clean with a damp cloth wrung in a solution of water and a neutral detergent. Remove soap residue immediately using a clean, dry cloth.

- Avoid using scouring cream or scouring pads, as they may scratch the surface.

FABRICS

- Vacuum the furniture regularly to remove dust and avoid fluff and pilling. Wrinkles in the fabric can be straightened using a steamer.

- Soak up spilled liquids with an absorbent napkin or cloth by dabbing gently towards the centre of the stain.

- Use a lint-free cloth wrung in lukewarm water to remove stains. If necessary add a little neutral detergent. Avoid rubbing the material hard as this could result in loss of colour and damage the fabric.

- Use a hairdryer to avoid leaving an outline.

- Never use concentrated detergents or bleach, ammonia or soap intended for hard surfaces.

SILK LEATHER

- Silk is an aniline leather which means that it has no or only a light surface treatment to preserve the leather's natural surface and soft touch.

- Vacuum regularly using the upholstery nozzle. Be careful not to scratch the leather.

- All natural markings, such as scars and insect bites, will be visible on aniline leather, which contributes to the leather's exclusive appearance.

- This kind of leather is very susceptible to dirt, and over time it will patinate and become slightly darker.

- Aniline Leather is demanding to maintain, and we recommend that you keep a cleaner and care product suitable for this type of leather at hand.

- Using water may leave a permanent stain on the surface.

- Do not use sharp objects, strong detergents or solvents on the leather.

> PARTS 1 SEATER <

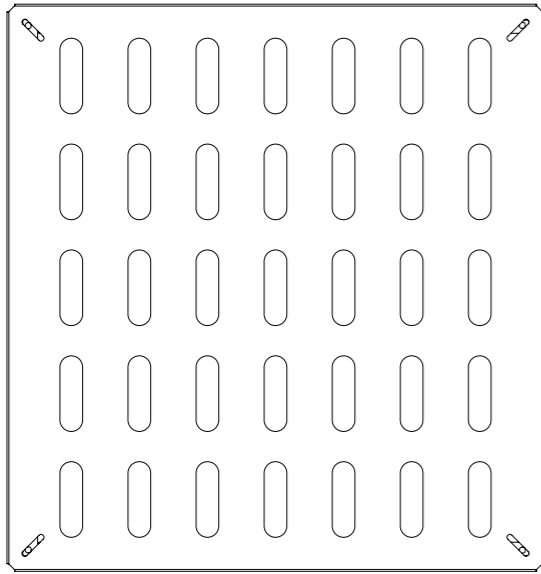

Seat frame (A) x 1



Front leg (B) x 2

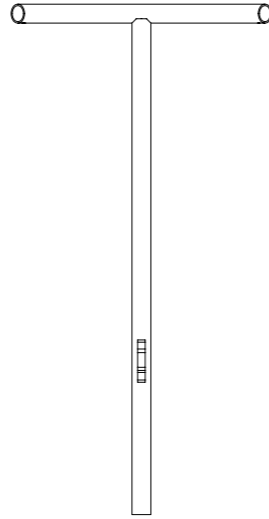

Back leg (C) x 2

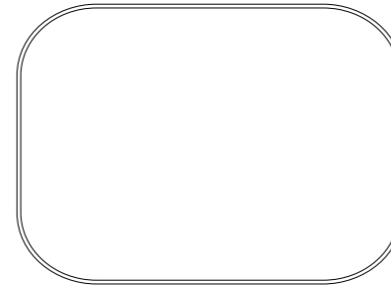

Side pillow (G) x 2

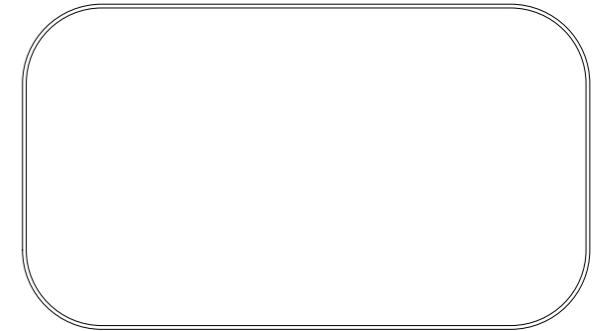

Back pillow (H) x 1

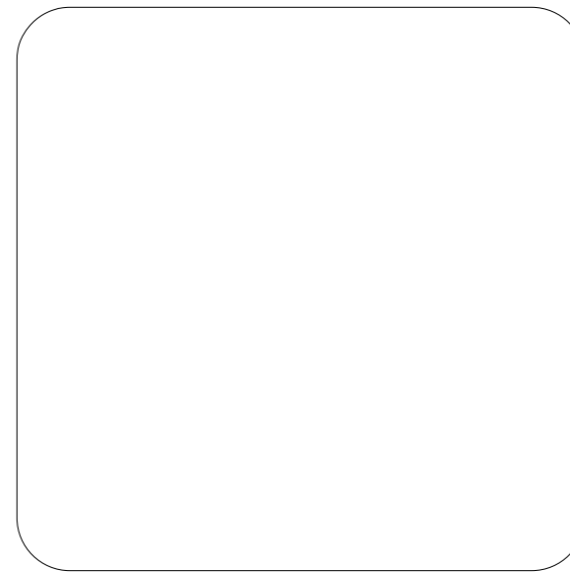

Seat pillow (I) x 1

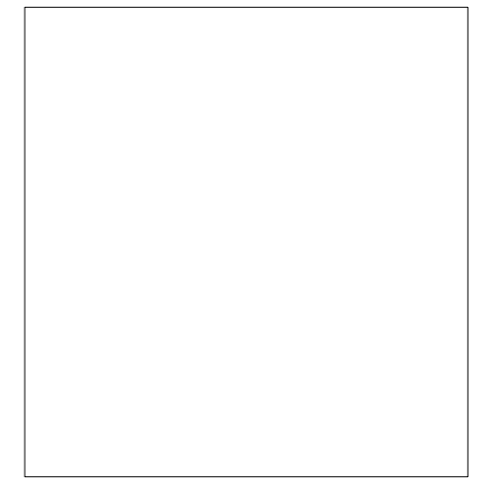

Anti slip mat (J) x 1



Arm rest tube (D) x 2



Back rest tube (E) x 1

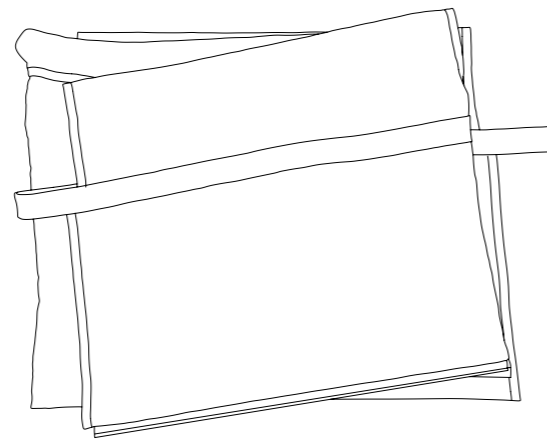

Canvas (F) x 1

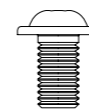

Screw (K) x 12



Allen key

> PARTS 2 SEATER <

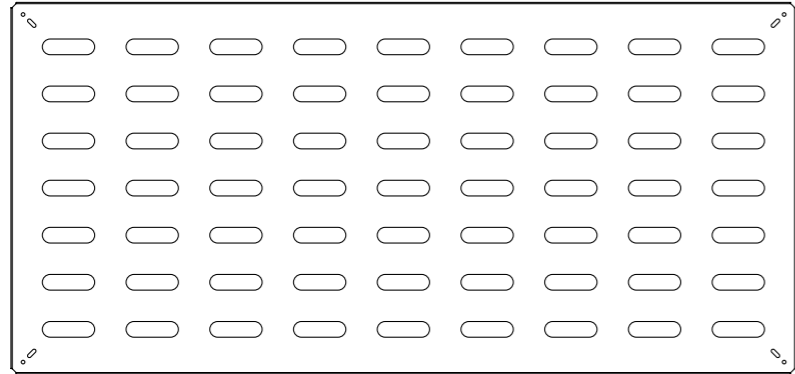

Seat frame (A) x 1

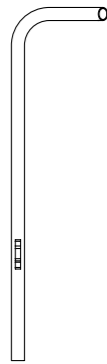

Front leg (B) x 2

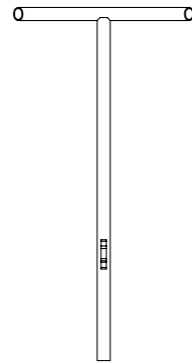

Back leg (C) x 2



Arm rest tube (D) x 2



Back rest tube (E) x 1

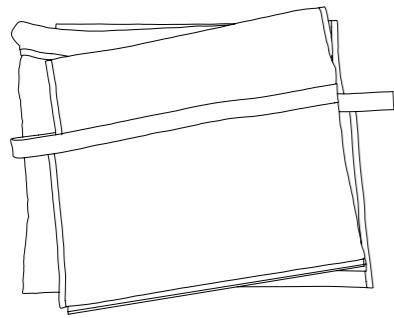

Canvas (F) x 1

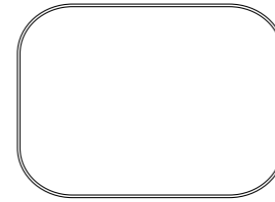

Side pillow (G) x 2

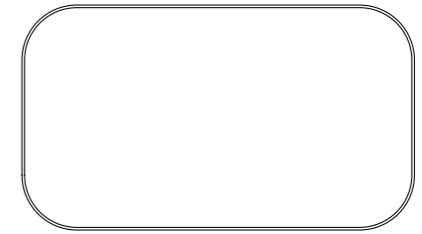

Back pillow (H) x 2



Seat pillow (I) x 1

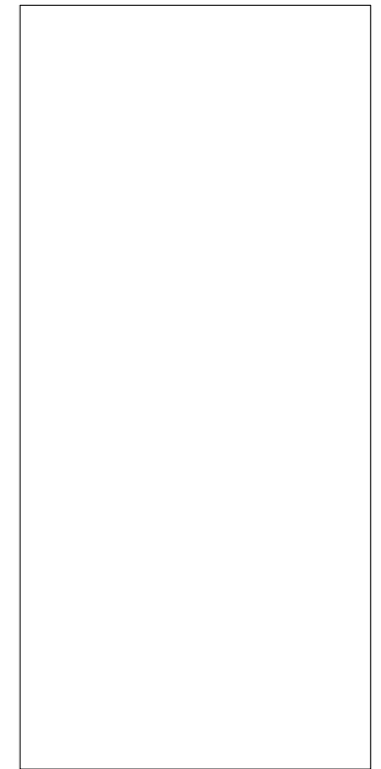

Anti slip mat (J) x 1

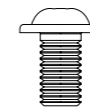

Screw (K) x 12



Allen key

> PARTS 3 SEATER <

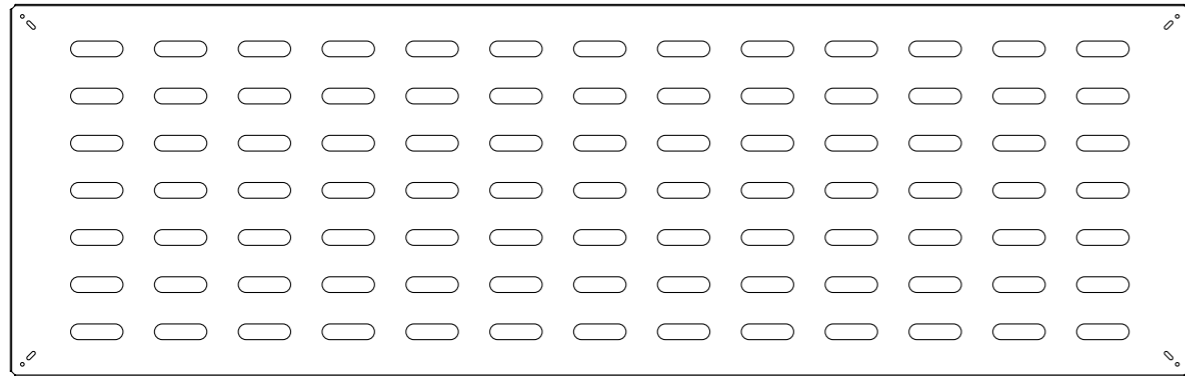

Seat frame (A) x 1

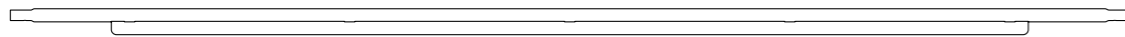

Back rest tube (E) x 1

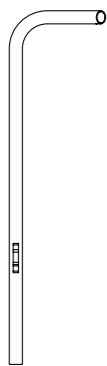

Front leg (B) x 2

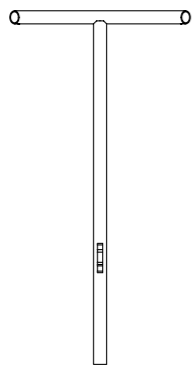

Back leg (C) x 2



Arm rest tube (D) x 2

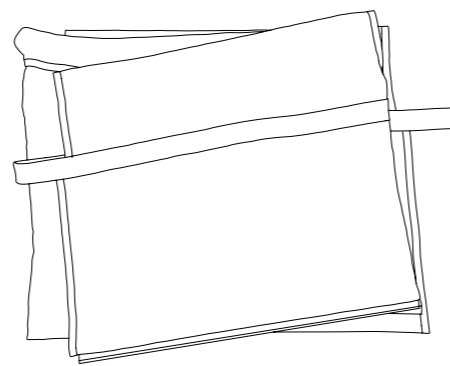

Canvas (F) x 1

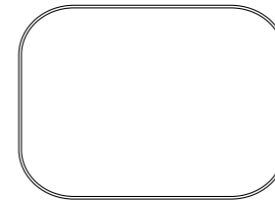

Side pillow (G) x 2

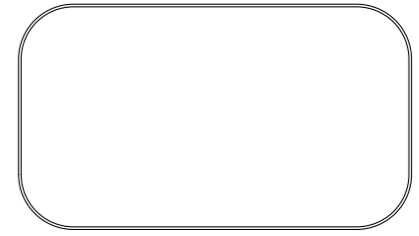

Back pillow (H) x 3

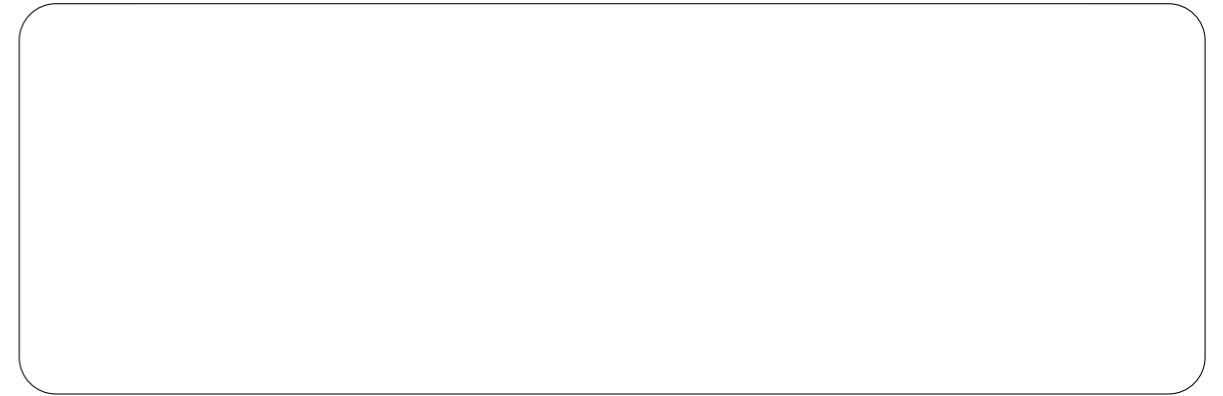

Seat pillow (I) x 1



Anti slip mat (J) x 1



Screw (K) x 12



Allen key

1.

Locate the backside of the seat frame (A), marked with a white sticker, and insert the back legs (C) into each back corner.

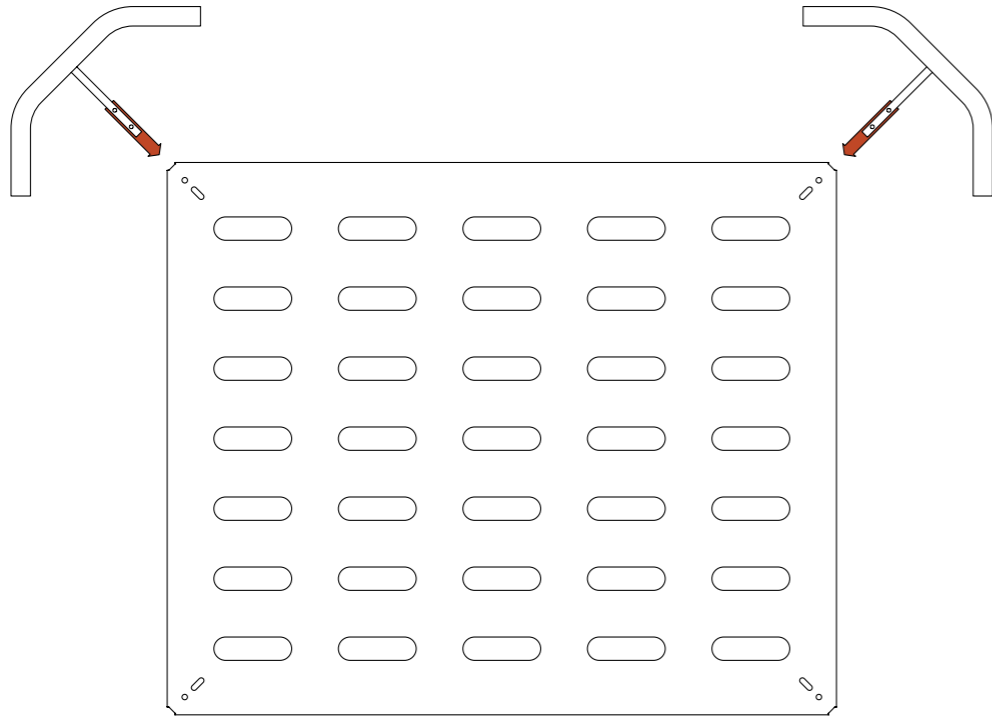

2.

Secure the back legs (C) to the seat frame (A) by slightly fastening one screw (K) in the hole closest to the centre of the sofa.

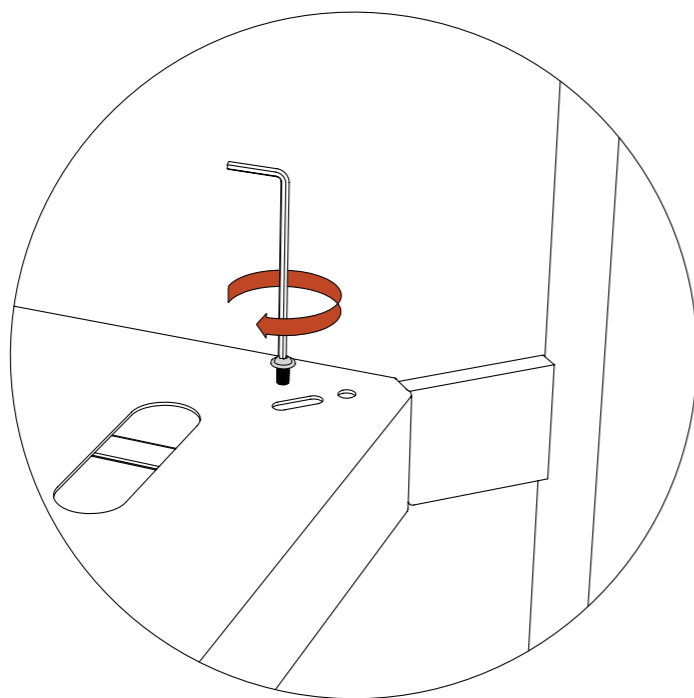

3.

Pull the legs gently outwards.

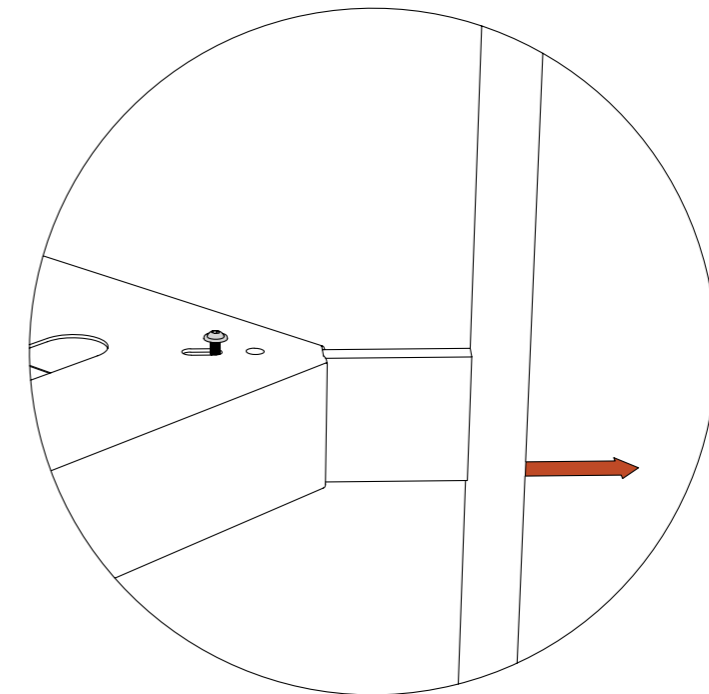
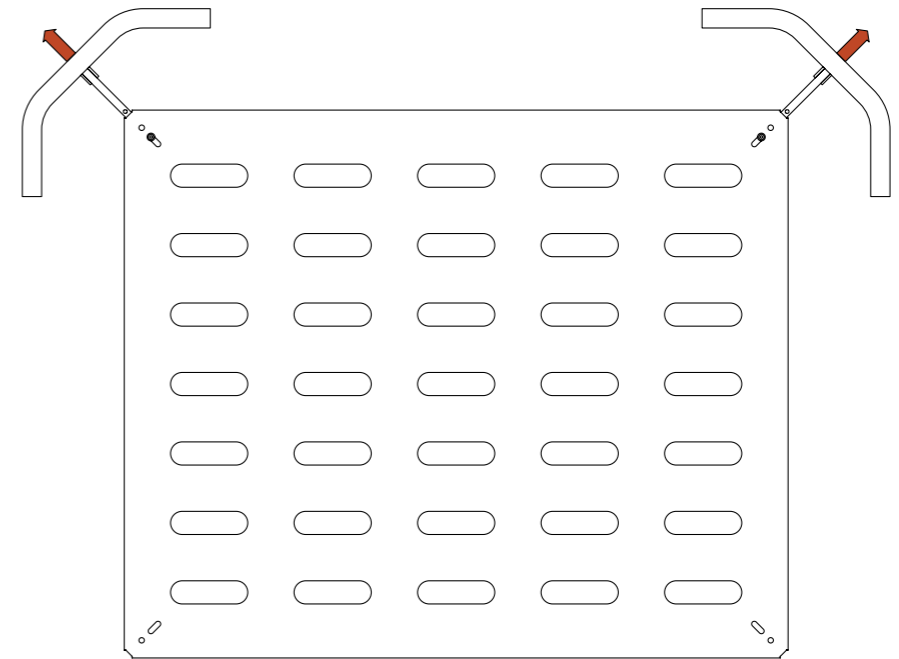

4.

Insert the back rest tube (E) into the middle part of the canvas.



2 and 3 seaters: Make sure the back rest tube (E) is facing the right way. The back rest tube (E) is marked with a white sticker that should face the outside of the sofa.

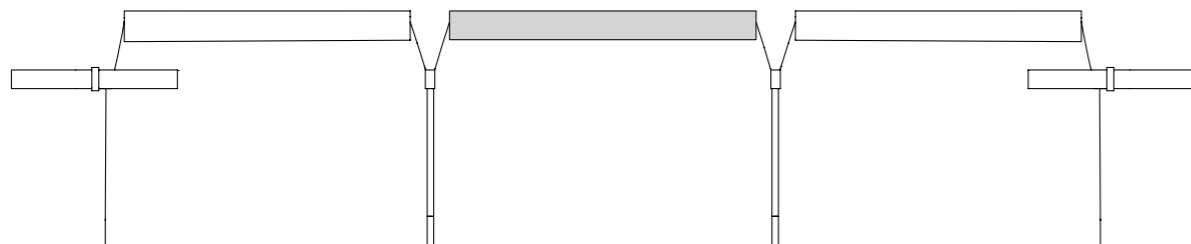
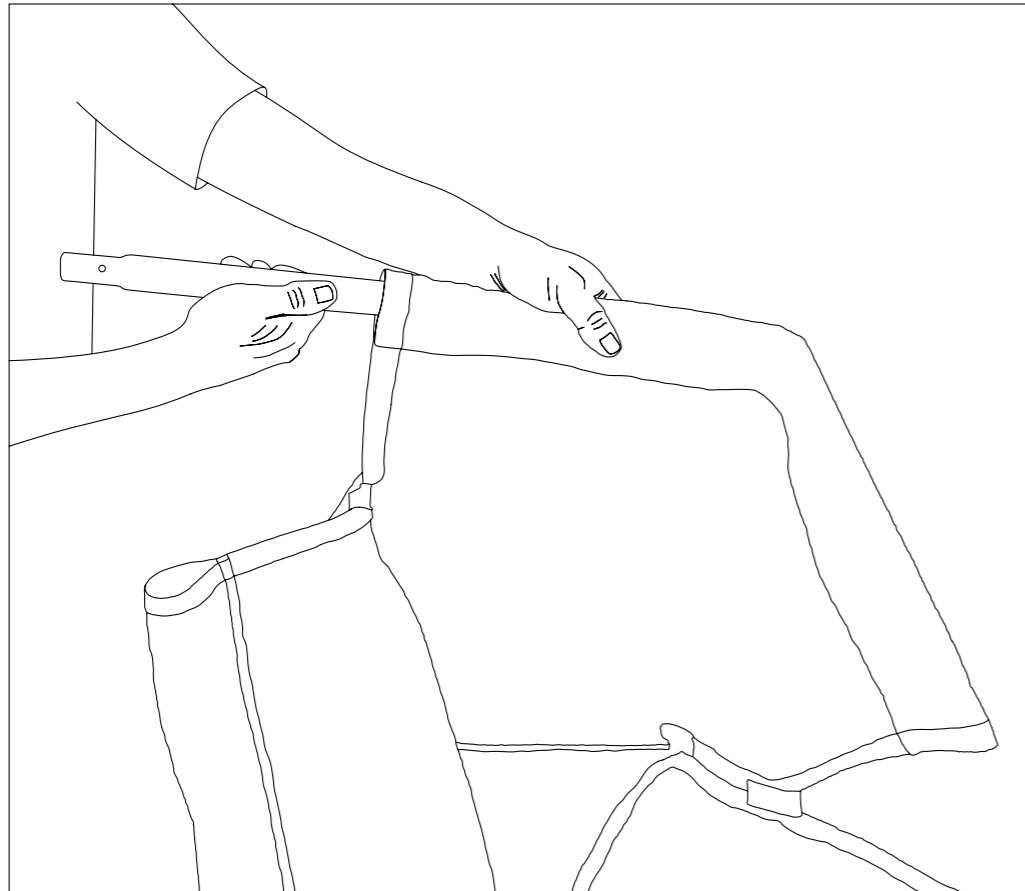

5.

Insert the back rest tube (E) into both back legs (C). Make sure the canvas is mounted with the cotton strap facing outwards. Twist E to hear a "click".

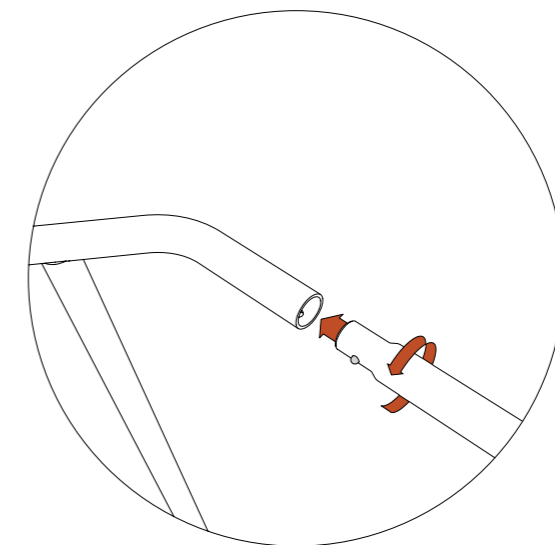
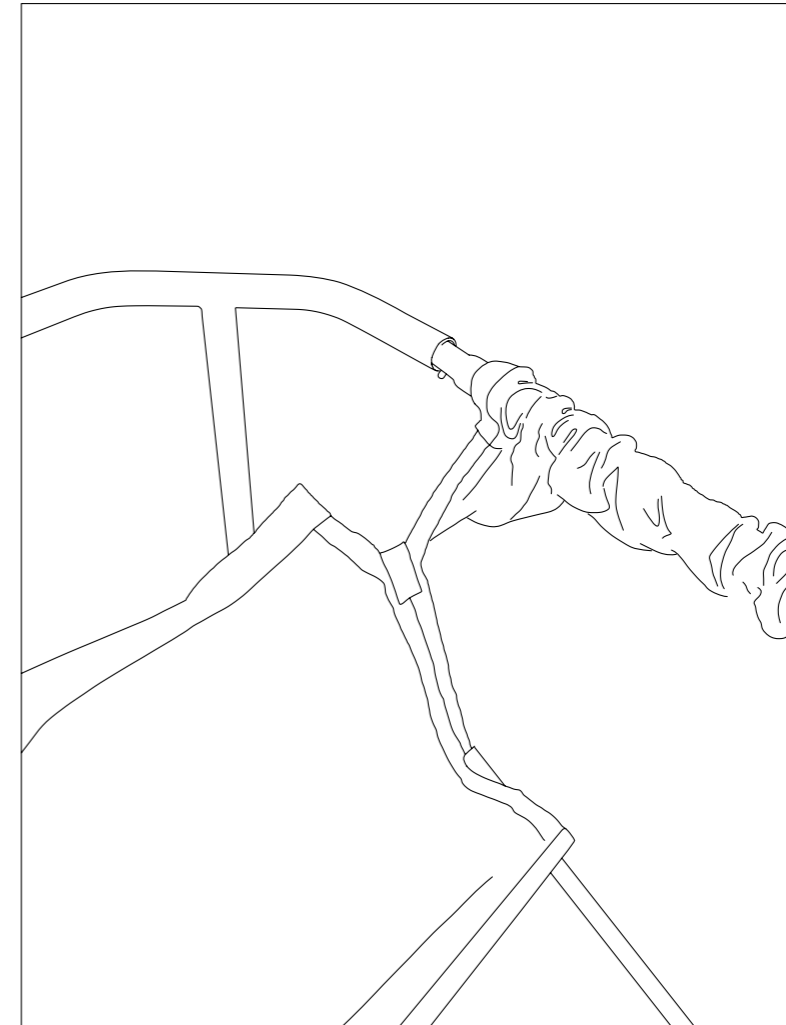

6.

Insert the arm rest tube (D) into the canvas.
Make sure the canvas is kept on the inside of the back leg (C).

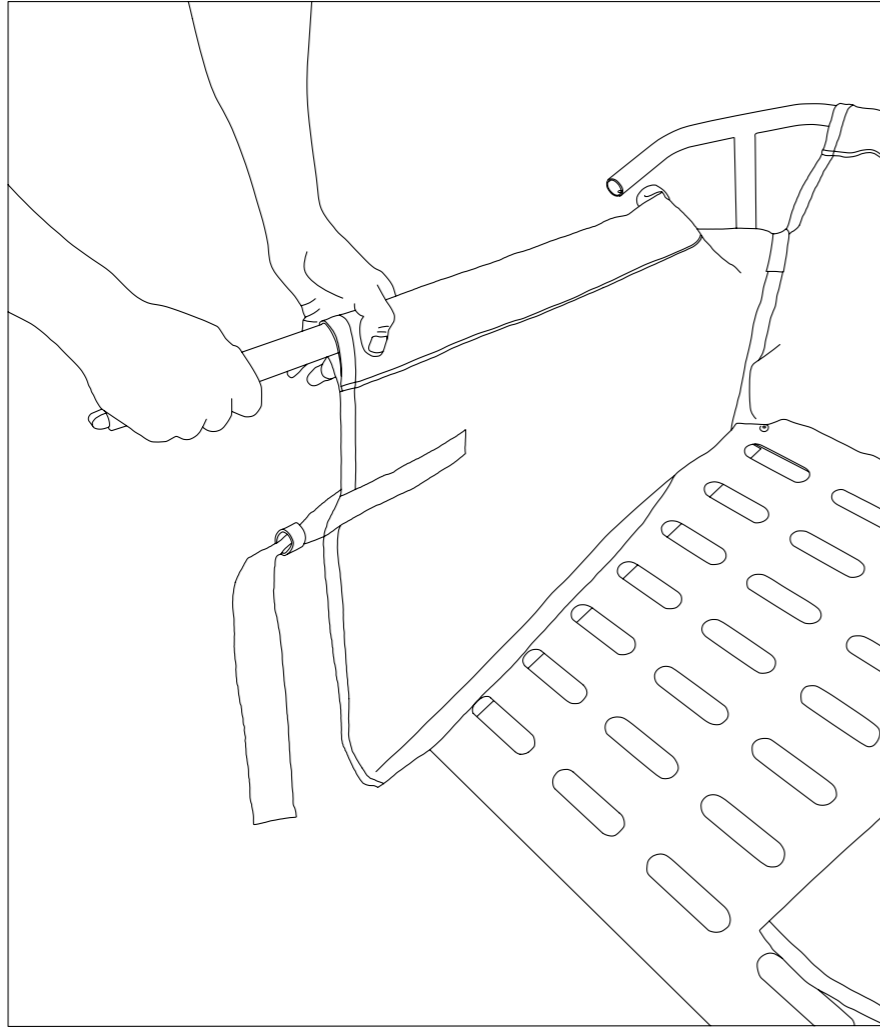

7.

Insert arm rest tube (D) into back leg (C).
Twist D to hear a "click".

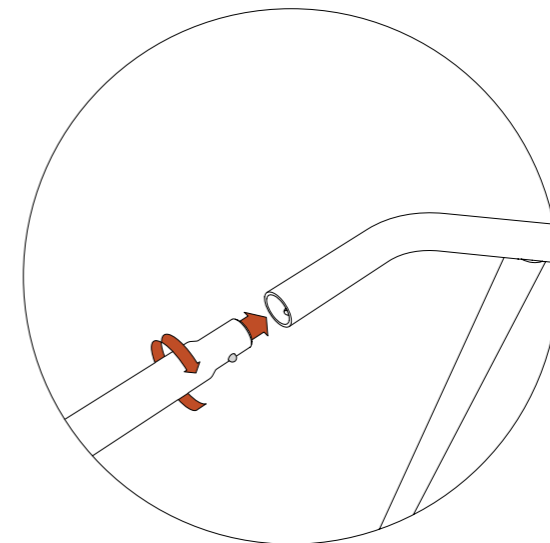
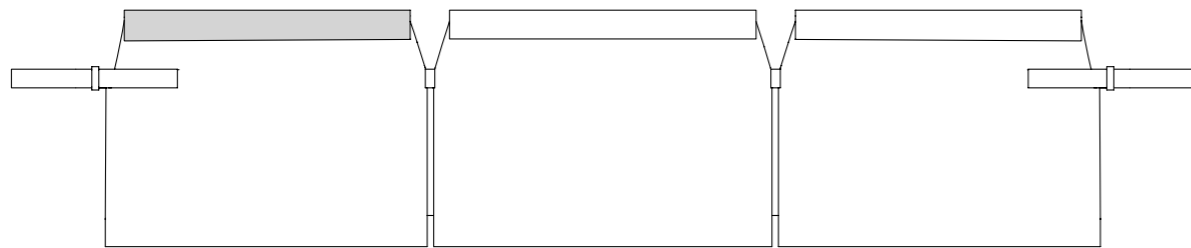
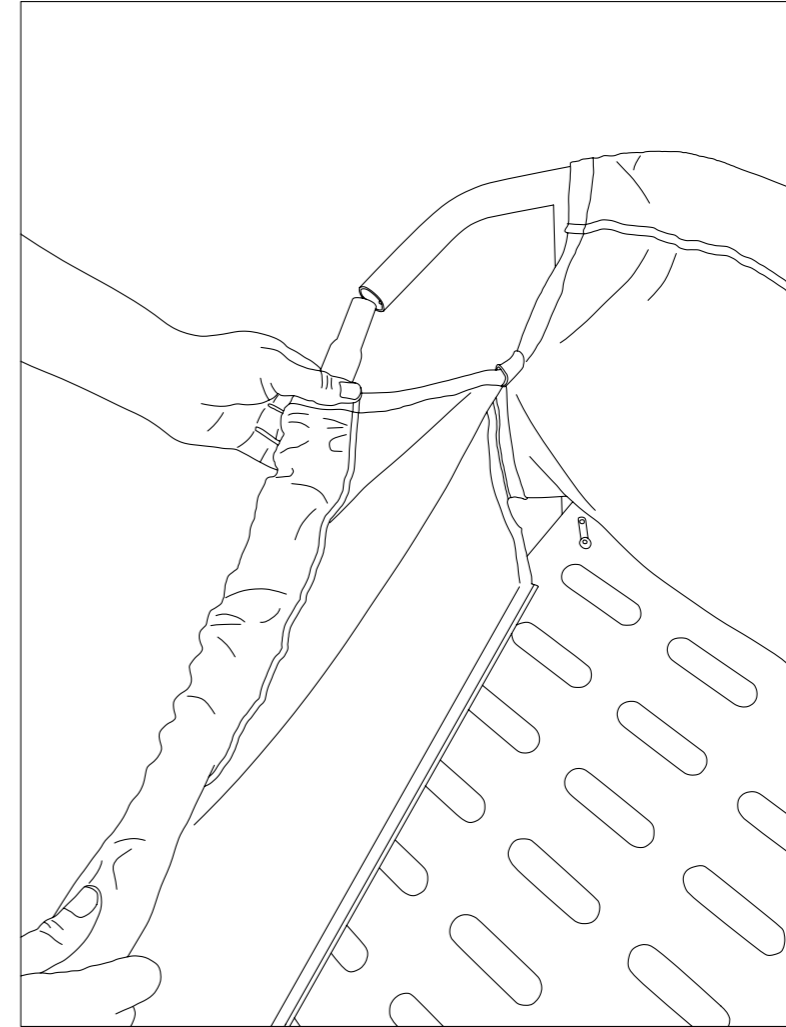

8.

Insert front leg (B) gently into the frame (A) and armrest tube (D).
Repeat step 6, 7 and 8 on the other side.

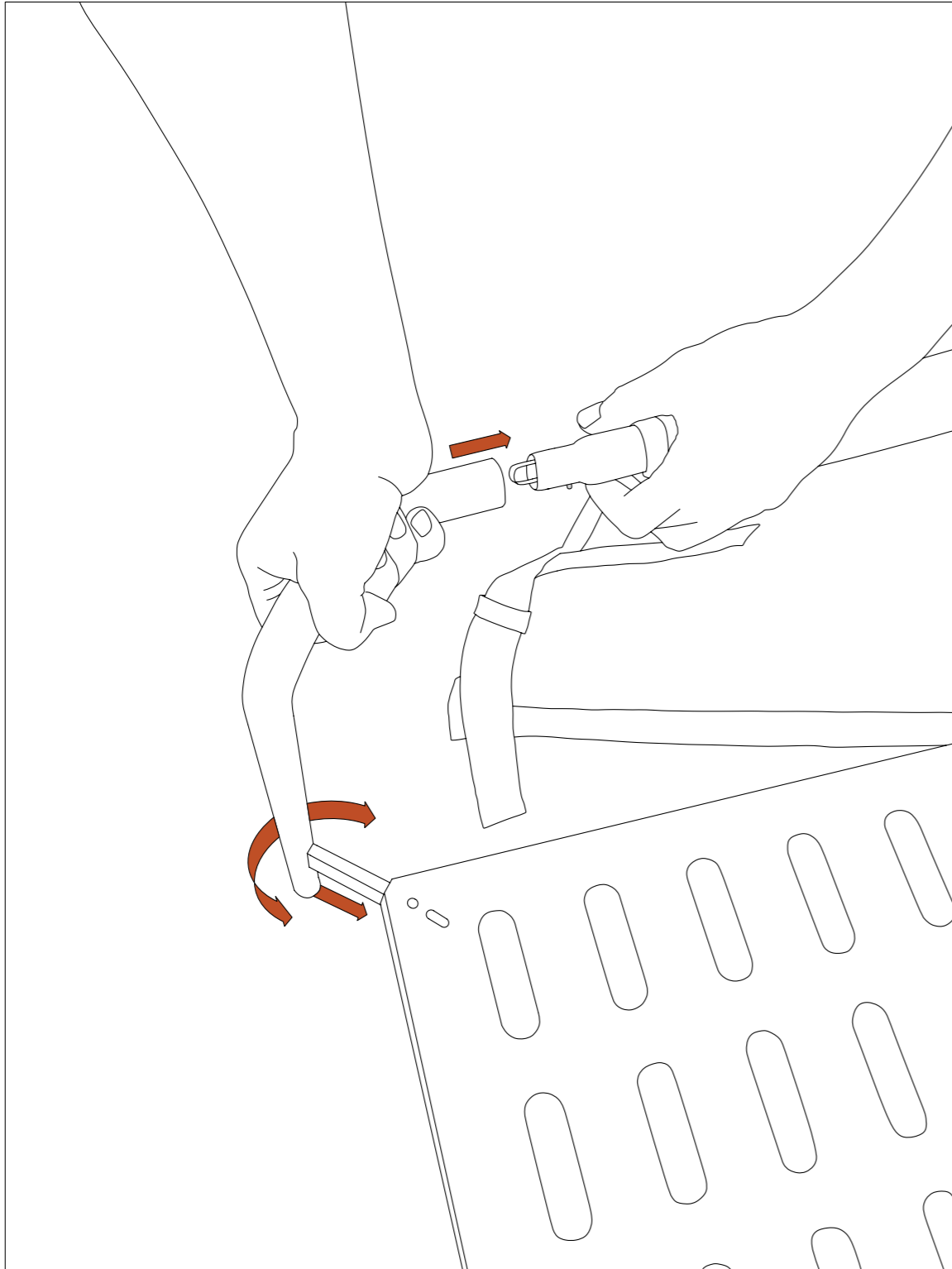

9.

Gently secure front legs (B) and back legs (C) to the frame (A) by fastening screws (K) in all four corners.

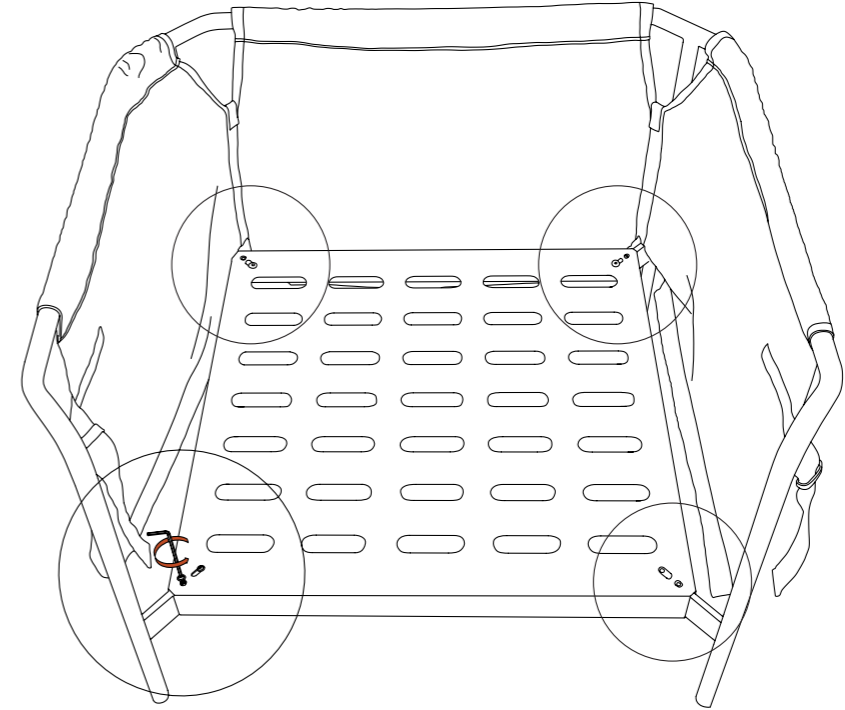

It is important NOT to tighten the screws completely yet.

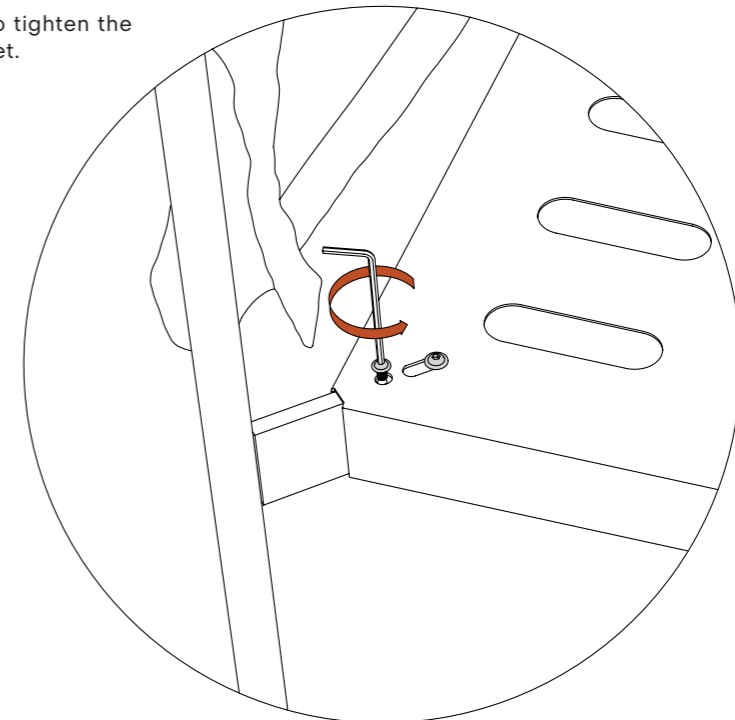

10.

Flip the frame forward to ease access to the bottom of the seat frame. Make sure to place it on the box to avoid scratching the frame.

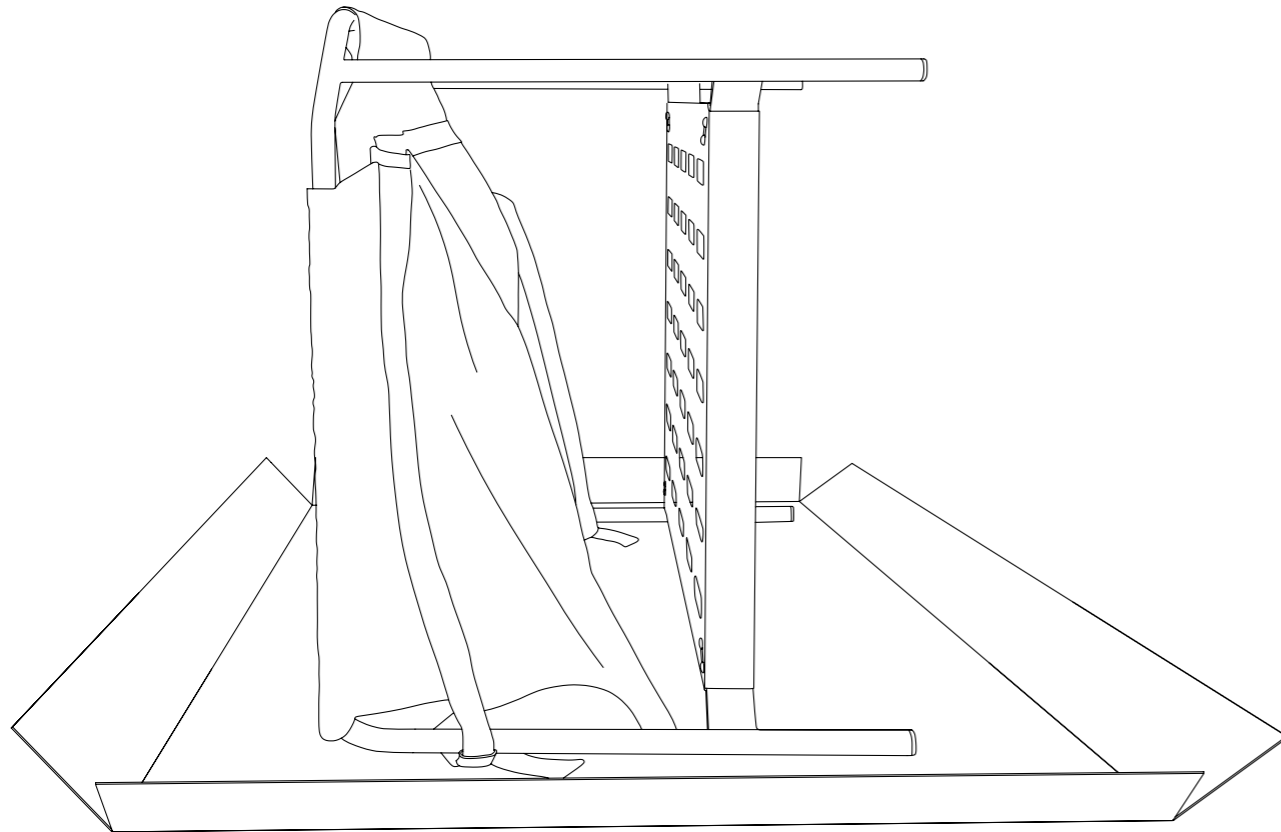

11.

Secure front legs (B) and back legs (C) to the frame (A) from the bottom side by fastening screws (K) in all four corners.

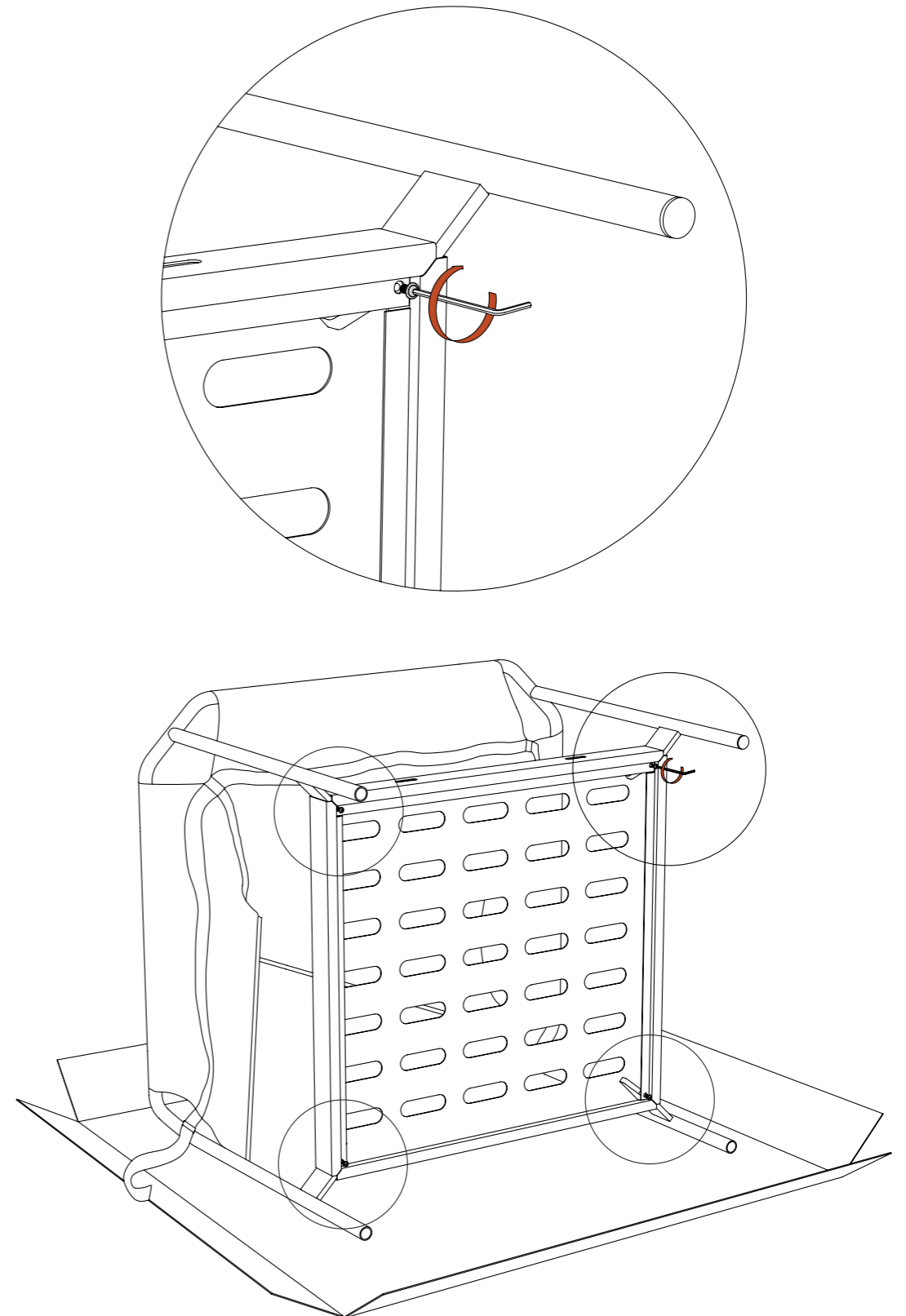

12.

MOUNTING CANVAS

Slide the plastic profile onto the bottom of the seat frame. It is important to start in one end and work your way to the opposite side. Make sure the canvas is stretched all the way to the corners.

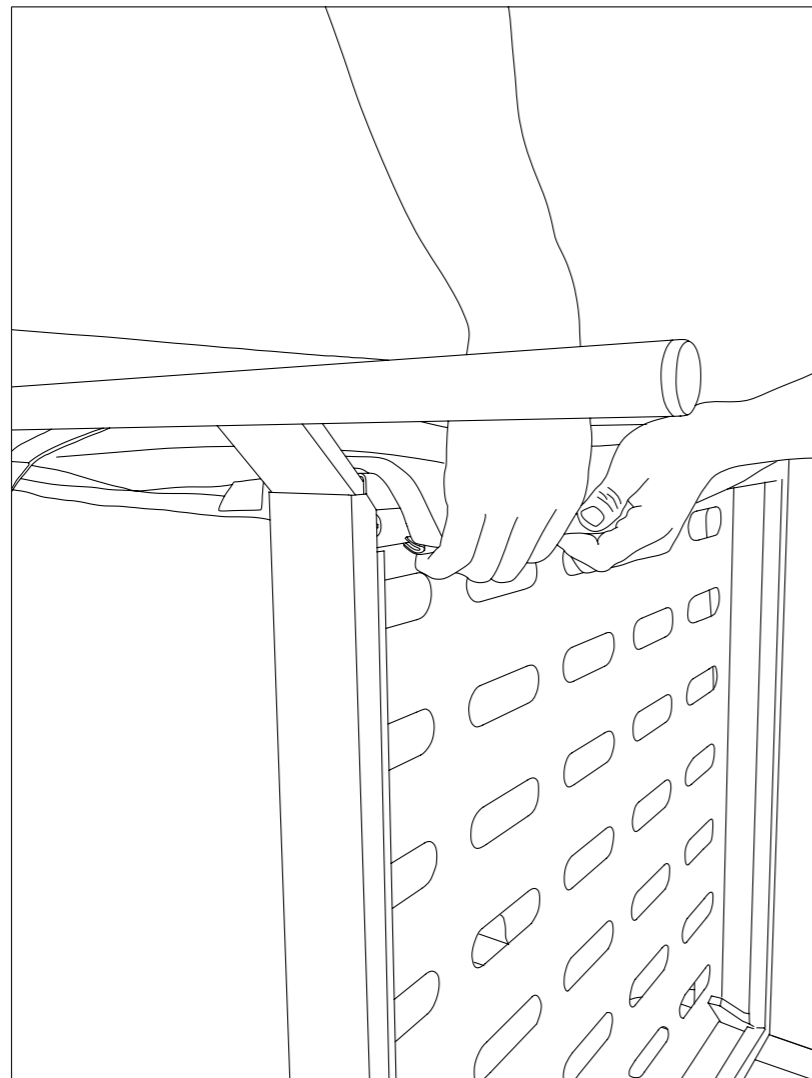
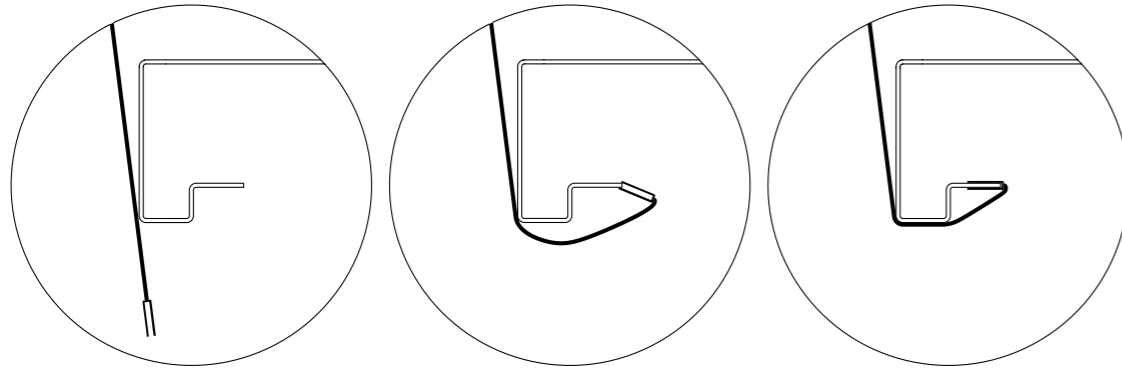

13.

MOUNTING CANVAS

Slide the plastic profile onto the bottom of the seat frame. It is important to start in one end and work your way to the opposite side. Make sure the canvas is stretched all the way to the corners.

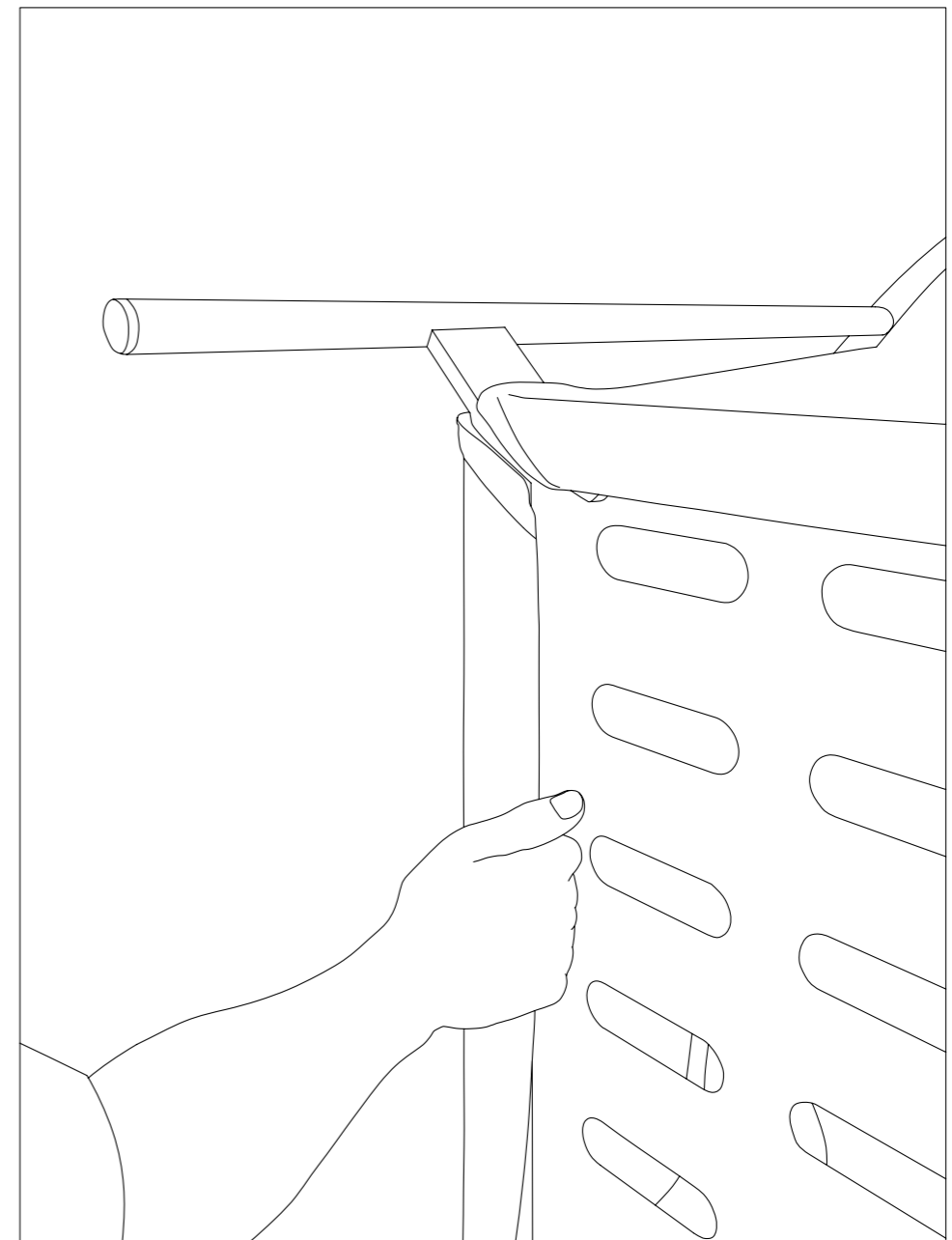

14.

Secure the front legs (B) and back legs (C) to the frame (A) by fastening the screws (K) in all four corners.

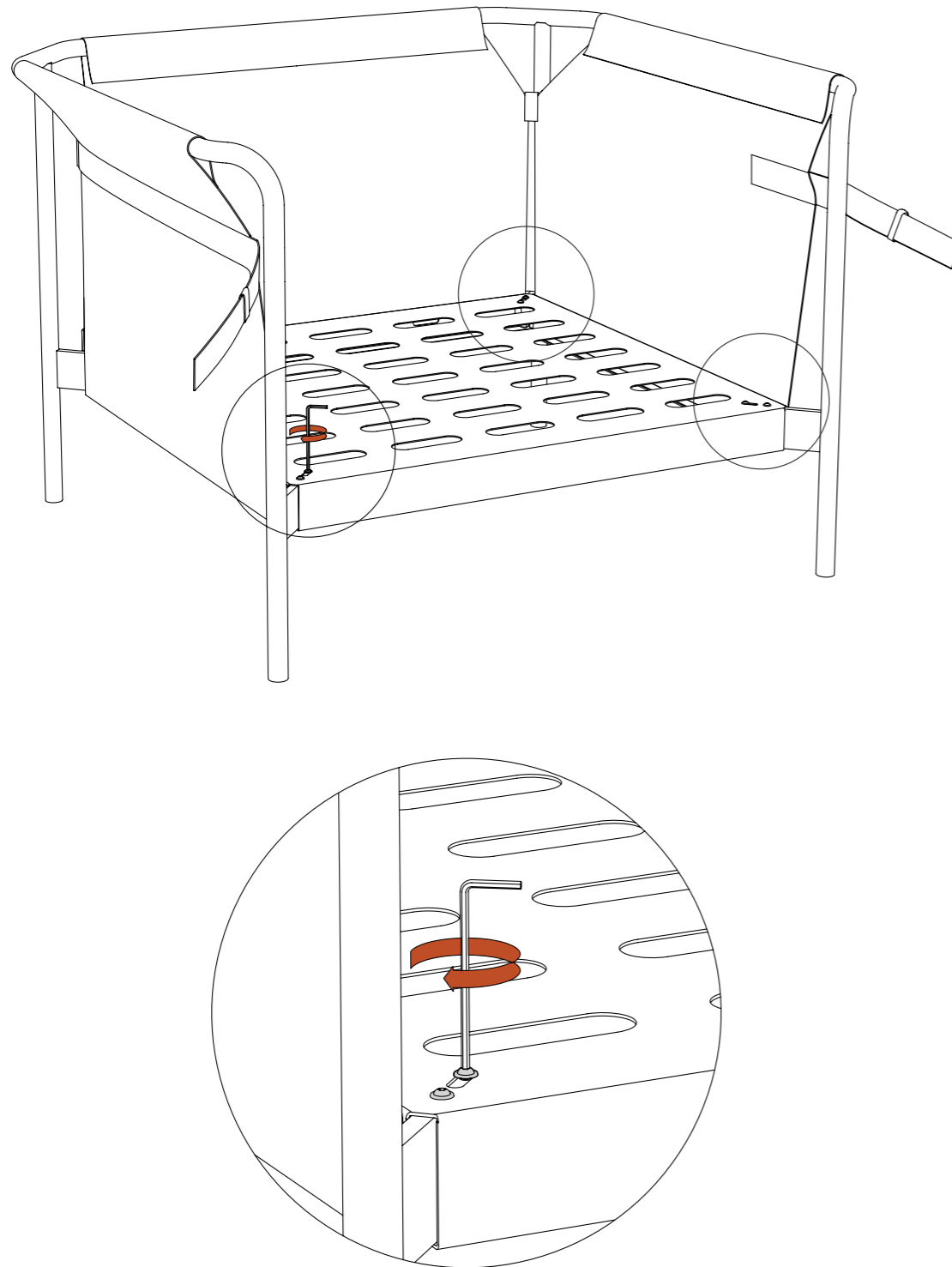

15.

MOUNTING CANVAS

Place the cotton strap around the front leg and slide it through the leather ring. Adjust the canvas and then tighten it by pulling the cotton strap and fastening it to the Velcro.

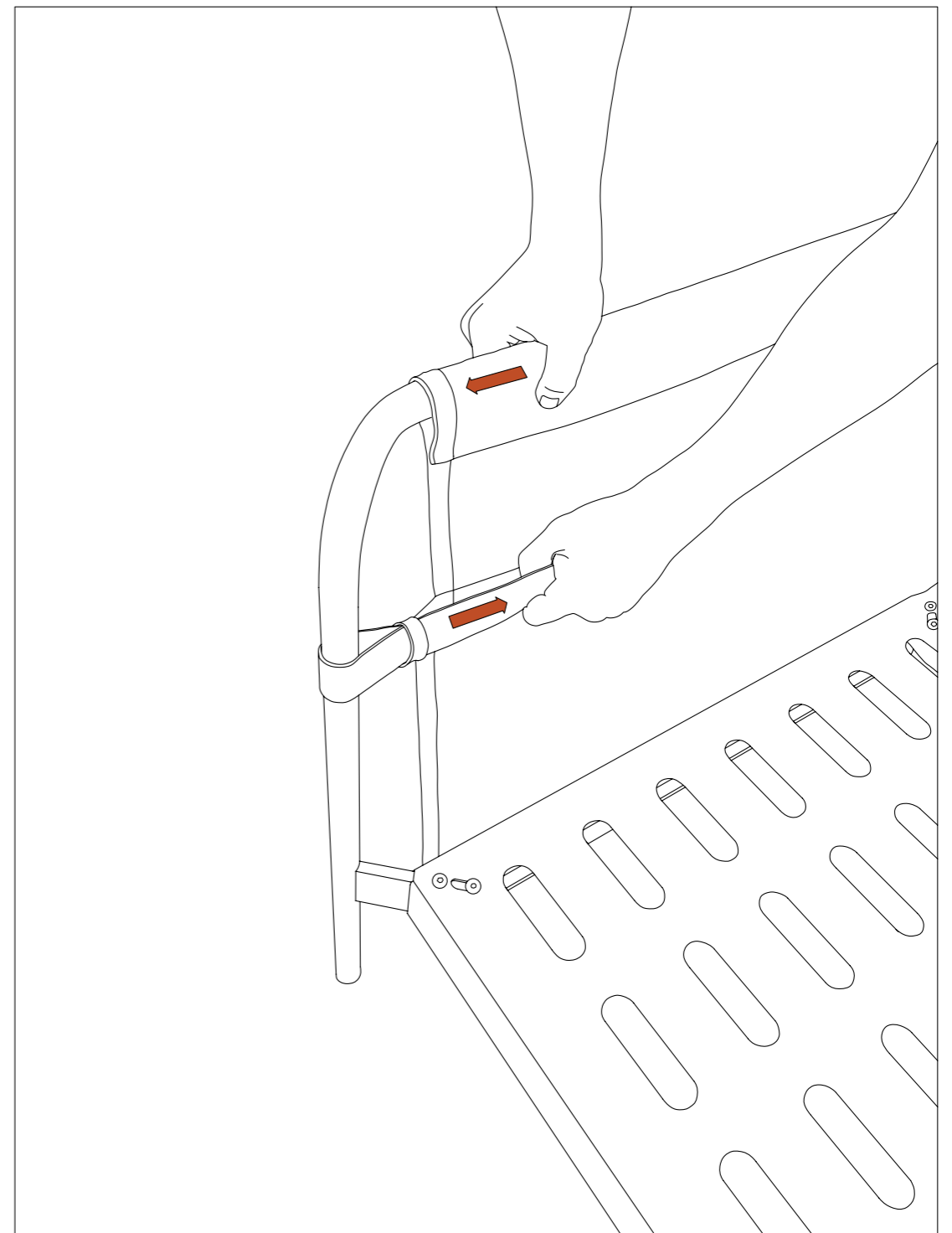

16.

ADJUSTING CANVAS.

Adjust the canvas on the frame. Start in one end and work your way to the opposite side.
Make sure the canvas is not folded or misplaced anywhere.

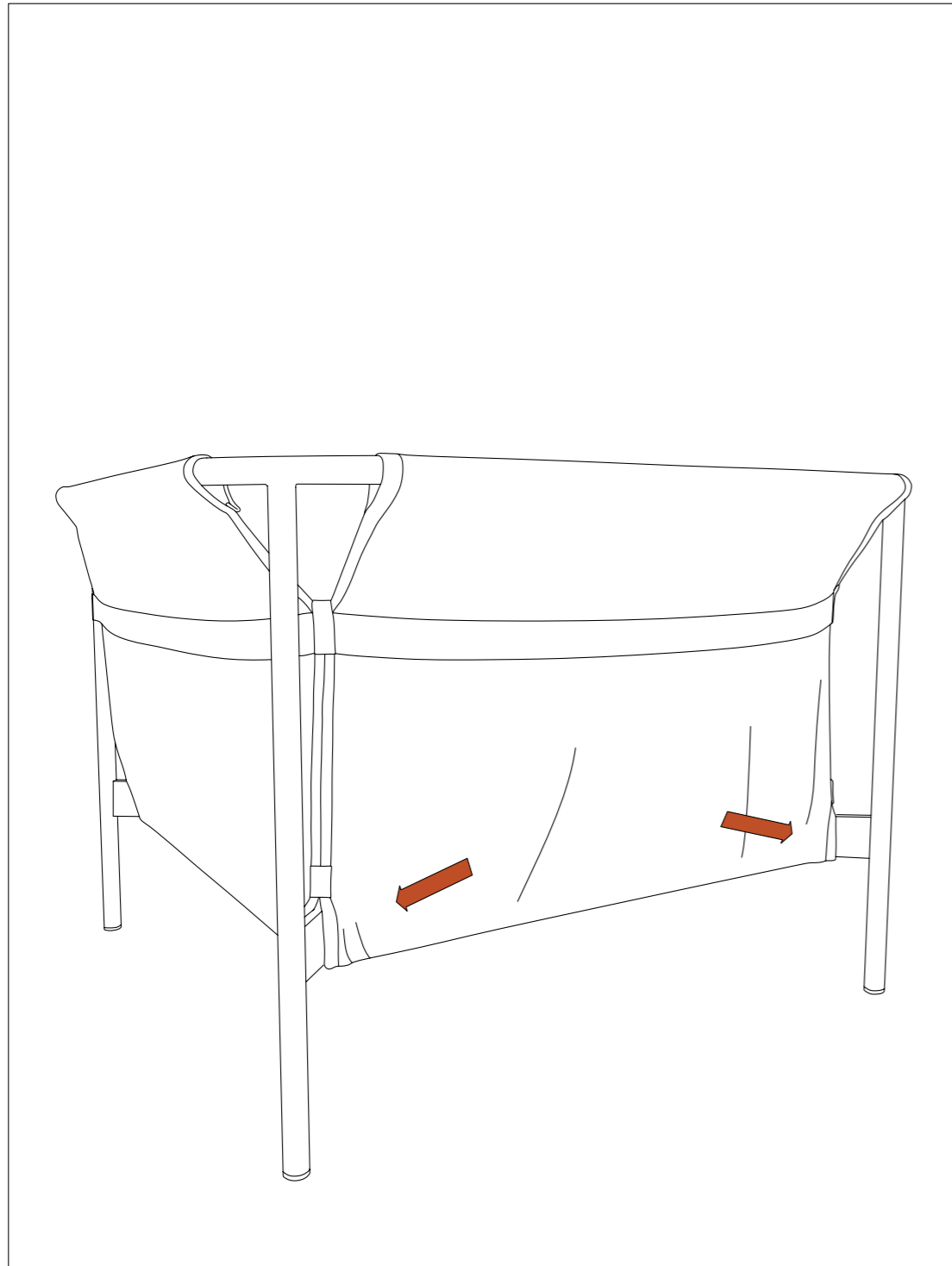

17.

Place the anti-slip mat (J) in the center of the frame.

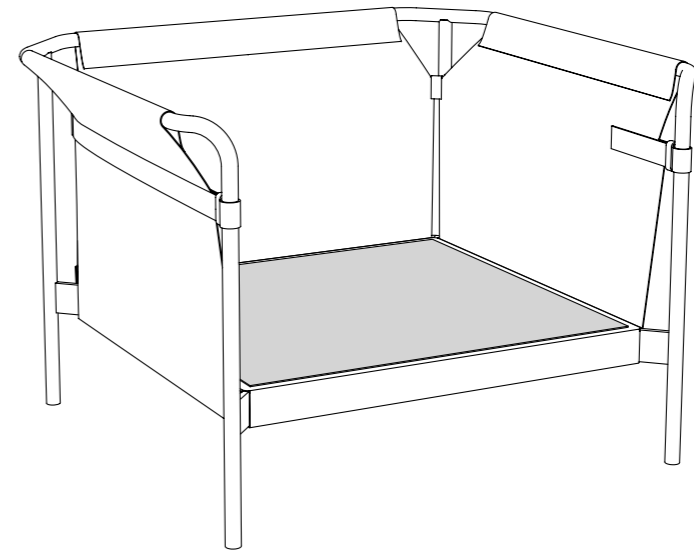

18.

Place the seat pillow (I), back pillow (H) and side pillows (G) in the frame.

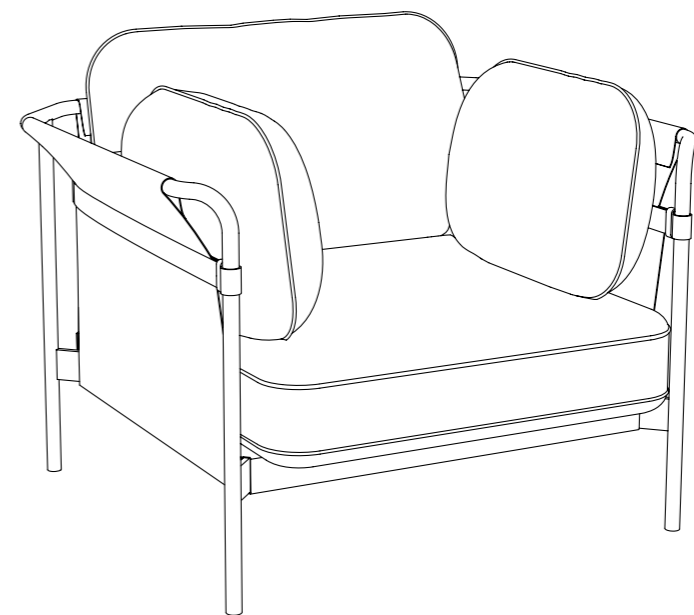

17.

Over time, your sofa will need some attention to ensure that the cushions are plump and the seat cushion keeps its shape. Straighten out any creases and lumps in the seat cushion with your hands.

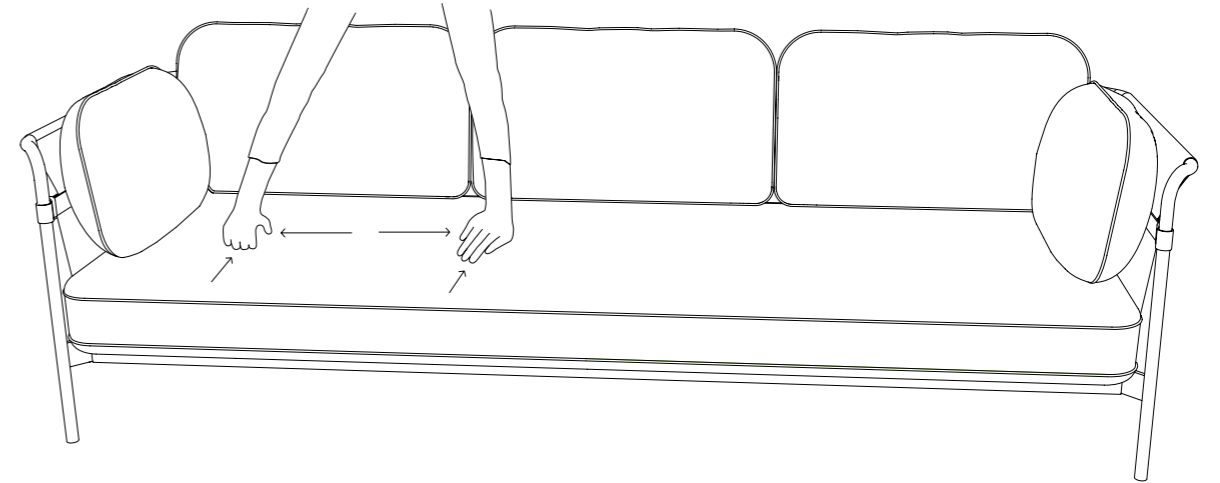
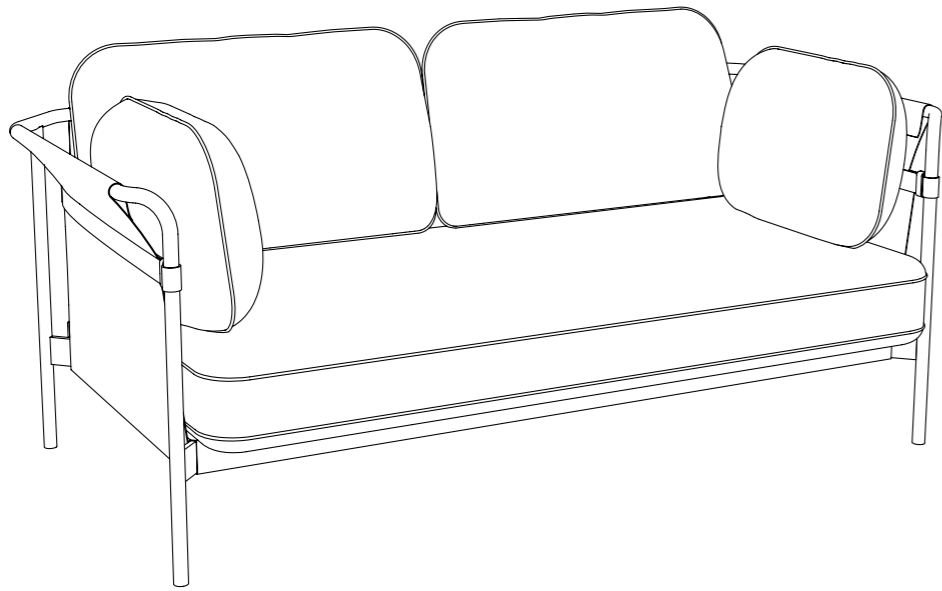

18.

Plump the cushions regularly.

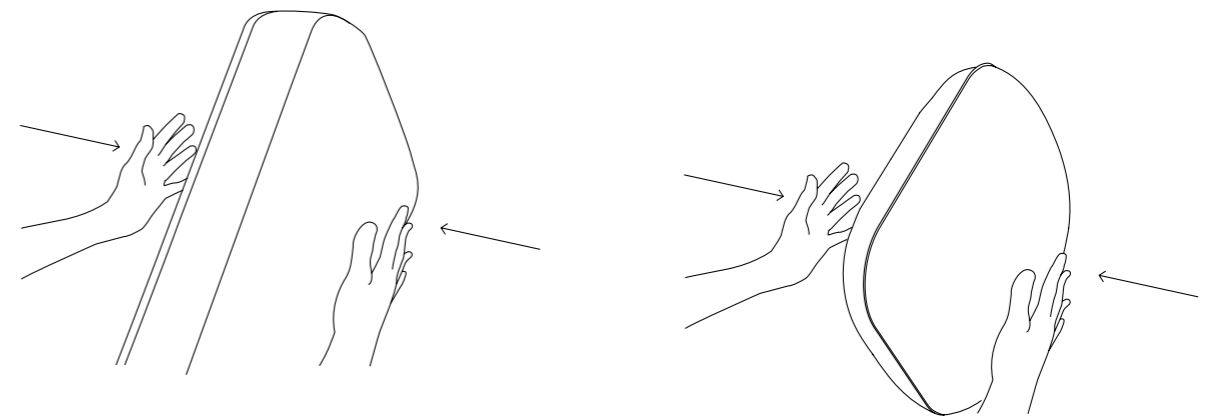
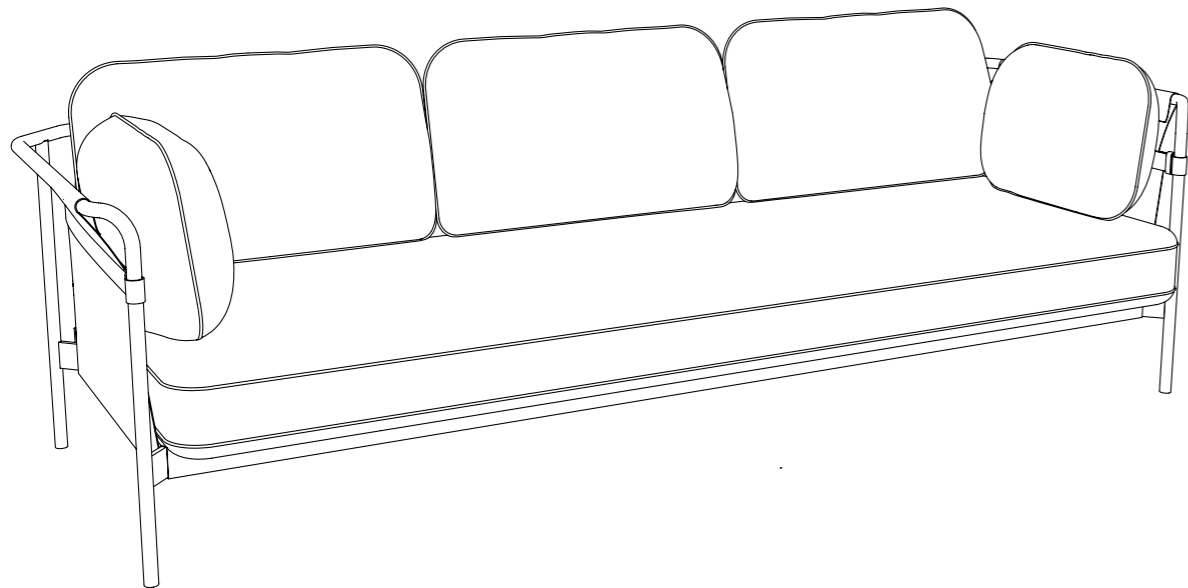



Havnen 1 8700 Horsens Denmark
+45 4282 0282 / hay@hay.dk

HAY

ITEM NO. 706327



5 710441 209669